

Course Syllabus

Small Engines

William E. Cattin Instructor

Course: Small Engines, IET 215, 4 Credits

Hours: MWF 8:00AM – 9:50AM

Room: Power Technology Lab

E-mail: cattinw@cwu.edu

Office phone: (509) 963-1911

Power Lab phone: (509) 963-1770

Office 301 Hogue Technology Bldg.

Home: 962-8370

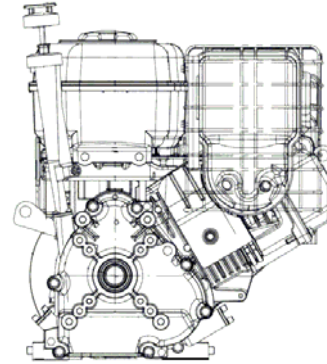

Text: Engine Blueprinting, Rick Voegelin, SA Design

Course Description:

This course covers theory of operation, disassembly, inspection, assembly, and tuning of small gasoline fueled engines. Emphasis will be placed on understanding the universal principles of induction, efficiency, compression, emissions control; exhaust, camshafts, valvetrain, and tuning that are common to all internal combustion engines.

Demonstrations will be performed to show the operations of replacing valve seats, seals, gaskets, and grinding of valves and stem ends.

Small engines can be used to learn all of the techniques and skills for blueprinting, and engine rebuilding that are necessary for any size engine. Working with small engines saves storage space, student dollars, solvent, consumables, glass beads, and most importantly headaches. Consideration will be given to students possessing experience, money, time and motivation to work on larger engines. Machining and measuring techniques will be learned and combined with proper application they can be applied to rebuild or repair any piece of machinery.

This course may be the most radical “small engines course” encountered in your educational career. Major emphasis will be on blue printing and high performance techniques that are use by the top line engine builders. Cleanliness, precision, “doing it the right way” and the “**Sano Approach**” will be stressed. It is close to magical to take a beat up bone yard dirty engine and bring it all the way back to being a beautiful piece of painted, machined and tricked out mechanism.

Safety and Consumables

It is required that all students either wear their own prescription eyeglasses or safety glasses during demonstrations and laboratory work. Safety glasses are available for purchase from the CWU Bookstore, Knudson Lumber, Tum-a-Lum lumber, NAPA, local rental outlets, and others.

- Any student found not wearing safety glasses, will have their grade reduced one letter grade and **all work by all students** will stop for the day!

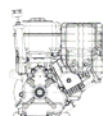

- ❑ The Power Tech Lab provides an extensive set of tools, however, specialty or a good set of hand tools may make your day much smoother. Secure storage is available for student use.
- ❑ Each student must provide their own supply of:
 - Shop towels (Al's, Car Quest, NAPA...)
 - Shop apron, coveralls, or shop coat (used from Car Quest!)
 - Small containers for parts and pieces (boxes, baggies, reused cans...)
- ❑ It is strongly recommended that any student working on a typical "small engine" also purchase the appropriate manual for that engine (Honda, Tecumseh, Kohler, Onan, Wisconsin, Kawasaki, etc.) The Power Lab is only equipped to handle Briggs and Stratton engines. As a side note horizontal shaft engines are preferred to vertical shaft designs, but this is to be taken as a recommendation not a requirement.

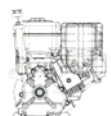
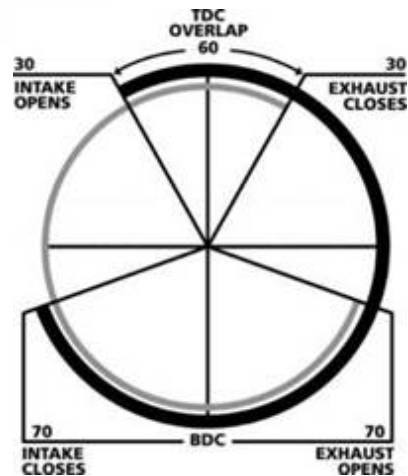
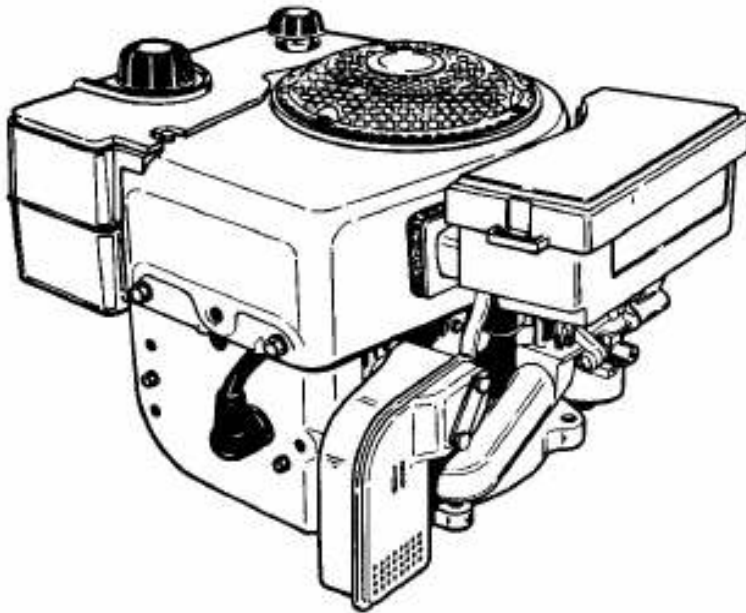

Course Topical Outline:

- 1) General Principles of Heat Engine Operation
 - i) Thermal principles
 - ii) Bore, Stroke
 - iii) Volumetric Efficiency
 - iv) Torque, Horsepower, Mechanical efficiency
- 2) Nomenclature
 - i) Piston
 - ii) Connecting Rod
 - iii) Rings
 - iv) Camshaft
 - v) Crankshaft
 - vi) Magneto
 - vii) Lifters
 - viii) Rocker arms and followers
 - ix) Valves
 - x) Valve springs
 - xi) Valve retainers
 - xii) Valve guides
 - xiii) Valve retainers
 - xiv) Flywheel
 - xv) Timing gears, chain or belts
- 3) System Functions
 - i) Fuel
 - ii) Lubrication
 - iii) Ignition
 - iv) Cooling
- 4) Precision Measurements
 - i) Valve Lift
 - ii) Combustion chamber volume
 - iii) Ring end gap
 - iv) Ring side clearance
 - v) Runout and out of round
 - vi) Fasteners
- 5) Tuning and emissions control
 - i) Idle adjustments
 - ii) CO/HC measurements
 - iii) Combustion efficiency measurements
 - iv) High speed adjustment
- 6) Carburetor Competency Checklist
- 7) Photocopy a drawing of your specific carburetor
- 8) Show the choke Show the throttle
- 9) Show idle speed screw adj. Show idle mixture screw
- 10) Show high speed screw Show high speed jet (main)
- 11) Trace air flow path Show fuel paths
- 12) Explain action of float/needle assembly Show main and idle fuel flow paths

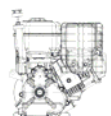

Course Objectives:

At the conclusion of the course the students will be able to:

1. Define the concepts of bore, stroke, compression ratio, volumetric efficiency, displacement, thermal efficiency.
2. Disassemble, and reassemble a small gasoline engine such that; (a) all parts are assembled correctly, (b) all fasteners are torqued correctly, (c) no threads are stripped, and (d) the engine runs and accelerates without hesitation.
3. Operate the following hand tools; combination wrenches, sockets, ratchets, torque wrench, ridge reamers, ring expanders and compressor, valve spring compressor, valve seat cutter
4. Operate the following precision measurement instruments; feeler gage, wire gage, dial indicator, telescope gage, small hole gages, dial calipers, micrometers.
5. Operate the following diagnostic and test equipment; compression tester, ignition analyzer, tachometer.
6. Identify correctly 20 parts of a small gasoline engine.
7. Describe the machining processes that can be used to increase/decrease displacement, compression ratio, and volumetric efficiency.
8. Tune and adjust the idle, low speed, and high speed circuits of the carburetor.
9. Detect runout, out of round, and calculate the clearance between shaft and plain bearing.
10. Measure/calculate bore, stroke, compression ratio, ring side clearance, ring end gap, crankshaft end play, and magneto air gap.

Course Assignments:

Written Examinations—2 @ 350 pts each (700)

Engine Restoration—200 pts

This will be done as per the Task Completion Record. All tasks will be completed in line with the Mastery Learning approach, where 100% mastery must be achieved by each student. The student should have his/her own engine. Regardless of whether the engine is a “keeper” or literally a throwaway, the engine should be the finest example of the engine builder’s art. The workspace should be clean and organized, operations will need to be scheduled, and storage systems of new and used parts will be developed by each student. If you complete all tasks early, you are free to do other tasks during class time!

Data Collection Sheet, Engine Precision Measurement—100 pts

This sheet will organize and lead you through a precision measurement and observation experience. “There are a million ways to ruin an engine rebuild and most of them are measured in thousands of an inch!” Disassembly and reassembly without measurement, observation, and judgment are by themselves, just about worthless. Do it right, do it once.

Grading Procedure:

This course is designed around a system of 1000 points total. Each learning assignment has been weighted and assigned a certain portion of 1000 points based on: the amount of work required/creativity required/importance to professional development/relative value of cognitive vs. psychomotor vs. affective domains

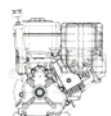

Grading Procedure:

The course is designed around a minimum of 1000 points, but could be more.

1. All assignments will be turned in on the day designated during class time for the course. No grade will be given for late work.
2. No make-up assignments or examinations will be allowed unless provisions for circumstances are made in advance of the date in question.
3. All written work will be evaluated on the following criteria:
 - a. neatness
 - b. spelling
 - c. content quality
 - d. completeness
4. Please ask questions if assignments are unclear. The final responsibility for misunderstandings and late work rests with the student.
5. Points will be assigned for each student's work. The total points obtained throughout the course will then be evaluated according to the following chart:

A	100-92%	A-	90-92%		
B+	88-90%	B	82-88%	B-	80-82%
C+	78-80%	C	72-78%	C-	70-72%
D+	68-70%	D	62-68%	D-	60-62%

6. Missing class is **not** "OK". Discussion questions, safety instruction, and instruction on equipment and instruments are all valuable and should not be missed. Absences cause expensive wear and tear on equipment, supplies and facility. Demonstrations on equipment and technique will not be given over.
7. All written work will be typed or word-processed double-spaced, with 1" margins. Papers will be stapled in the upper left-hand corner.
8. Appointments can be directly made with the instructor or E-Mail.
9. "Close" grades will be determined by attendance patterns, enthusiasm and willingness to learn.

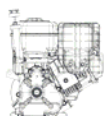

Small Engines
 Course Reading / Assignment Schedule
 (Keyed to Engine Blueprinting, Rick Voegelin)

Week #	Topic	Assignments Due
1	Engine Operating Principles	
2	Measuring and Testing Instruments	Read Chaps. 1,7,8
3	Ignition and Electrical Systems	Read Chaps. 2,3,4,
4	Carburetion and Related Systems	
5	Valve Service	Read Chaps.5,6,10
6	Laboratory Demonstrations by Instructor	Test #1
7	Solid Lab Work	
8	Solid Lab Work	
9	Solid Lab Work	*Engine and Data Collection Sheet due the last Regular Day of Class *Test #2 given during the regular final exam time. *Lab Cleanup during Final Exam time

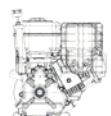

Your Name _____

Task Completion Record
Small Engines, IET 215

Directions: All of the following tasks must be performed in order to receive credit for any of them. Put a check mark in the circle in front of each task that you have completed. Have each task *Punched Off* by Cattin immediately after it has been completed.

- Be prepared to show CATTIN your work and explain what you did and the theory surrounding the operation. You will need to *understand* this operation.
- This is to be completed along with the Data Collection Sheet for Precision Measurement.
- If for some reason you can not perform the task on your own components, then you must perform it on another student's component!

- 1. Calculate your displacement, compression ratio
- 2. Chase the threads in block, using thread chasers
- 3. Swirl finish two valves
- 4. Cut a valve seat—three-angle valve job!
- 5. Dress one spark plug hole
- 6. "CC" your cylinder head
- 7. Degree the camshaft: DRAW 360 degrees of rotation, at 15 degree intervals
- 8. Check head and block for a flat plane, using precision bar
- 8. Remove and replace three piston rings
- 10. Disassemble and assemble the engine
- 11. Disassemble carburetor, clean and trace flow paths for CATTIN
- 12. Check for spark energy using the spark tester
- 13. Set idle speed, using electronic tachometer
- 14. Test condenser—leakage and capacitance
- 15. Paint engine (please only ON NEWSPAPERS IN THE SPRAY CABINET)
- 16. Start engine and tune carburetor; idle speed, idle mixture, main jet mixture (use Power Lab engine if necessary)
- 17. Test ignition coil high output voltage
- 18. Measure valve spring tension
- 19. Grind two valves
- 20. Countersink all threaded holes on your engine

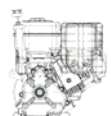

Your Name _____
Precision Measurement and Observation

This section is designed to be used by the student as a step-by-step analysis technique for evaluating the condition of a small gasoline engine.

The student must have a repair manual applicable to the engine on which he or she is working. From this repair manual the student will find the manufacture's recommendation which the student will report on this form under "should be" or "reject size" columns, along with answering questions concerning the general condition of engine parts.

Make of engine _____
Model _____
Type _____
Serial Number _____

Pre-disassembly checks

1) Crankshaft end play

Found _____

Should be _____

2) Does the engine have a "good observable spark"? ____

3) Initial compression, PSI _____

Disassembly Checks

4) Flywheel magnet to armature air gap

Found _____

Should be _____

5) Condition of flywheel key _____

6) Ignition breaker point gap

Found _____

Should be _____

7) Coil test: performed on the Graham Ignition Tester

Primary resistance _____

Secondary resistance _____

8) Condenser—performed on the Graham Ignition Tester

Microfarads _____

Leakage _____

Series resistance _____

9) Spark plug gap

Found _____

Should be _____

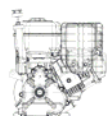

10)Condition of spark plug electrodes

11)Make and number of spark plug _____

12)Condition of cylinder head and head gasket

13)Valve stem diameter Ex _____ Intake _____

14)Valve guide diameter Ex _____ Intake _____

15)Valve guide clearance Ex _____ Intake _____

16)Valve tappet clearance

Found-intake _____

Found-exhaust _____

Should be intake _____

Should be exhaust _____

17)General condition of valves (stem, face, and margin)

18)General condition of valve seats and valve guides

19)Plastigage measurement between crankpin journal and connecting rod bearing at _
___ pound inches of torque. Width of Plastigage found _____

20)Piston ring groove side clearance, compression ring.
Measurement using feeler gage _____

21)Piston ring end gap
Top ring-found _____
Second ring-found _____
Bottom ring-found _____

22)Piston ring end gap—should be _____

23)Cylinder walls
Diameter, top _____

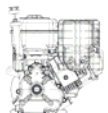

Diameter, bottom _____
Cylinder taper _____

24) Piston diameter, at top _____

25) Piston to cylinder wall clearance
Found _____
Should be _____

26) Crankshaft journal diameter, magneto side
Found _____
Reject size _____

27) Crank shaft journal diameter
Power takeoff side _____
Reject size _____

28) Crankshaft
Crank pin diameter _____
Reject size _____

29) Main bearing inside diameter
Magneto side _____
Reject size _____
Power takeoff side _____
Reject size _____

30) Crankshaft end play _____
After reassembly _____

31) Final compression after reassembly _____ PSI

32) Cylinder head torque sequence. Sketch the position of the head bolts.
Number bolts in recommended tightening sequence.

33) Head bolt torque _____
34) Connecting rod bolt torque _____
35) Flywheel nut/starter torque _____
36) Side cover bolt torque _____

